

**Coaxial coupling
for the metal
producing industry**

13-019



Coaxial coupling for applications in the metal producing industry – type 13-019

Gender	Part no.	End connection	l	n	t	D	AF
Adaptor	13-019-1-XX001-AAAB-Z02	G 1" British standard pipe parallel (BSPP) male thread to DIN ISO 228, sealing profile "E" to DIN 3852-11 for o-ring or sealing ring	71	32	18	37	41
Adaptor	13-019-1-XX003-AAAB-Z02	PG 21 IG	50	32	20	37	41
Protection cap	13-019-5-AAAC	—	71	—	—	58	46
Coupling	13-019-4-XX002-AAAA-Z02	PG 21 IG	71	—	16	58	46
Coupling	13-019-4-XX004-AAAA-Z02	Male thread M 42 x 1,5 for panel mounting and PG 21 female for cable clamp	134	—	55	58	—
Parking adaptor	13-019-6-WR033-AAAD	G 1" to DIN ISO 228	70	32	20	49	41

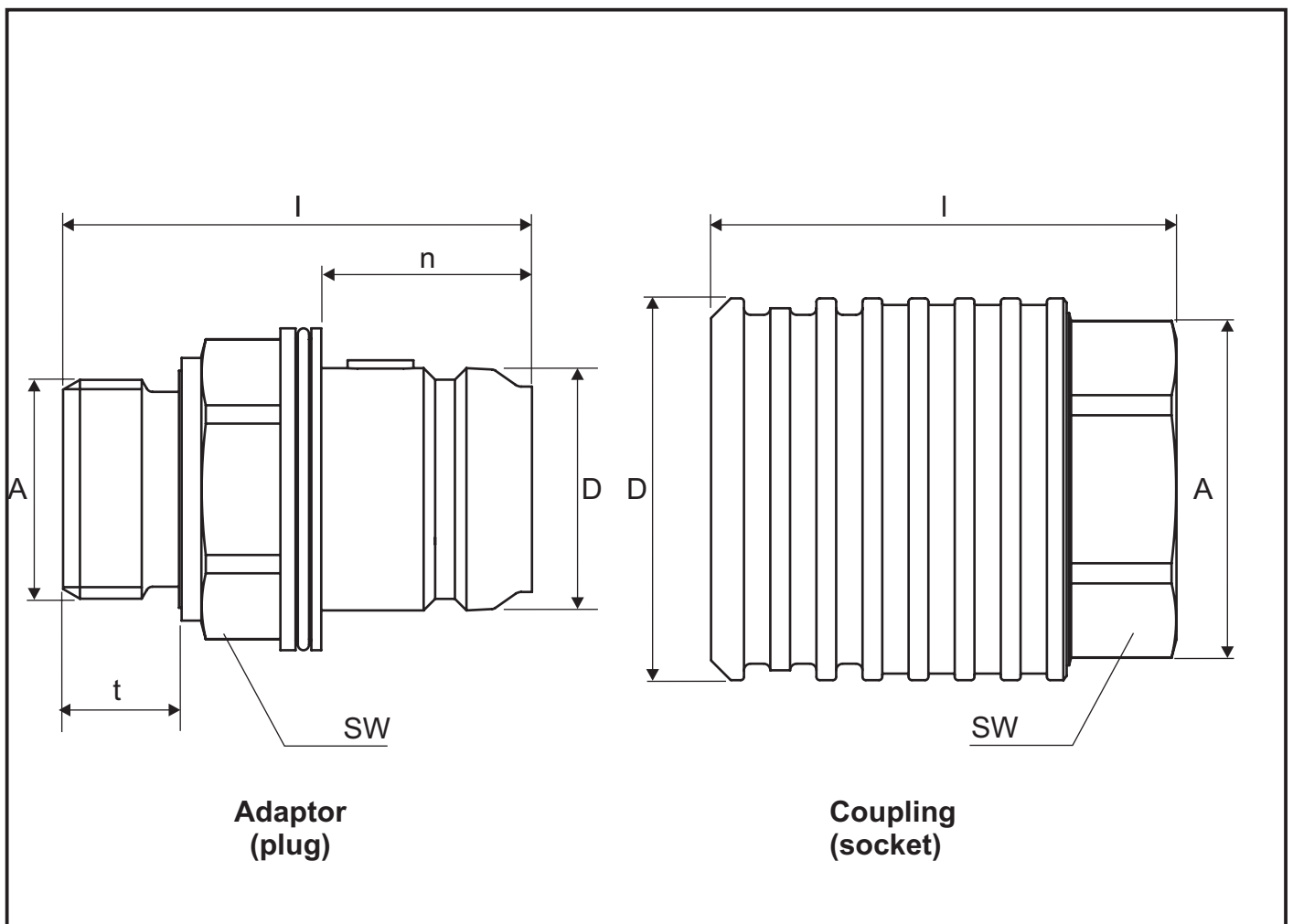

Coaxial coupling for applications in the metal producing industry – type 13-019

Description:

The coaxial coupling type 13-019 was especially developed to be used in the heavy duty environment of the metal producing industry. Air or nitrogen flows around a centrally positioned electro connector (7 or 12 way) and protects it from overheating. The electro cable is lead in a well protected way inside the air hose.

Simultaneously the ingress of dirt and moisture is prevented. The air pressure can also be used to protect electric switch boards and connection cabinets without having to install extra lines.

Features:

- rotational alignment secured by groove – shoulder alignment
- robust design
- dirt protected locking arrangement
- IP 65
- Electro connector with 7 contacts for max. 25V and 16 A, or 12 contacts for max. 25 V and 5 A
- simple assembly and wiring of electro contacts
- crimp connection for cables
- explosion protected when protective gas is used

Materials:

Housings – stainless steel 1.4404 (AISI 316 L)

Electro contacts – brass gold plated

Seals – high temperature FPM

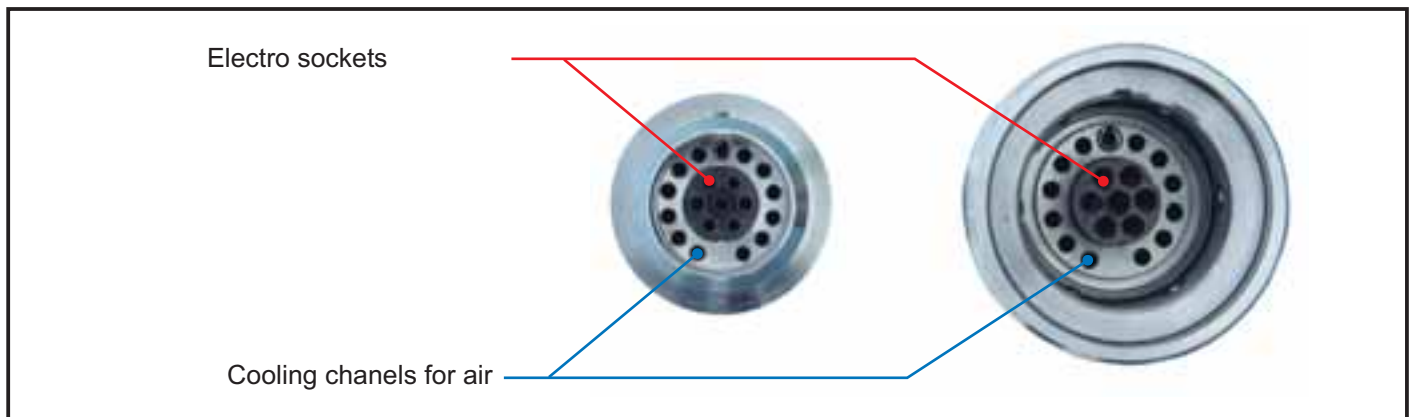

Protection cap



Plug side



Socket side



Parking adaptor

More applications in steel making



Clean break couplings series HP



Clean break coupling series CH



For each application the best suitable coupling



WALTHER PRÄZISION 07/2007 • subject to alterations • WKA

... and more than **300,000** other variations for all applications!

WALTHER-PRÄZISION Carl Kurt Walther GmbH & Co. KG

Hausadresse / Head office:

Westfalenstraße 2
42781 Haan, Germany

Telefon: +49 (0) 21 29 567-0
Telefax: +49 (0) 21 29 567-450

Postadresse / Postal address:

Postfach 420444
42404 Haan, Germany

eMail: info@walther-praezision.de
Internet: www.walther-praezision.de

